

Kramer Electronics, Ltd.



USER MANUAL

Rack Adapter Model:

RK-13

Contents

1	Introduction	1
2	Getting Started	1
3	Overview	1
3.1	Recommendations for Best Performance	2
4	Your Kramer RK-13 Rack Adapter	2
5	Mounting on the Kramer RK-13 Rack Adapter	3
5.1	Connecting a Blank Panel to the RK-13	4
6	Technical Specifications	4

Figures

Figure 1:	RK-13 Rack Adapter	2
Figure 2:	RK-13 Rack Adapter – Underside	3
Figure 3:	RK-13 Rack Adapter – Connecting a Blank Panel	4

Tables

Table 1:	Technical Specifications of the RK-13	4
----------	---------------------------------------	---

1 Introduction

Welcome to Kramer Electronics! Since 1981, Kramer Electronics has been providing a world of unique, creative, and affordable solutions to the vast range of problems that confront the video, audio, presentation, and broadcasting professional on a daily basis. In recent years, we have redesigned and upgraded most of our line, making the best even better! Our 1,000-plus different models now appear in 11 groups¹ that are clearly defined by function.

Congratulations on purchasing your Kramer **RK-13** rack adapter, which is ideal for mounting up to three 1/3-19" 1U units Kramer products in a 19" rack.

The package includes the following items:

- **RK-13 Rack Adapter**
- Additional mechanical parts (blank panel², screws, nuts and so on)
- This user manual³

2 Getting Started

We recommend that you:

- Unpack the equipment carefully and save the original box and packaging materials for possible future shipment
- Review the contents of this user manual

3 Overview

You can mount three 1/3-19" 1U Kramer products⁴ or two with one blank panel, or one with two blank panels in a 19" 1U rack.

1 GROUP 1: Distribution Amplifiers; GROUP 2: Switchers and Matrix Switchers; GROUP 3: Control Systems; GROUP 4: Format/Standards Converters; GROUP 5: Range Extenders and Repeaters; GROUP 6: Specialty AV Products; GROUP 7: Scan Converters and Sealers; GROUP 8: Cables and Connectors; GROUP 9: Room Connectivity; GROUP 10: Accessories and Rack Adapters; GROUP 11: Sierra Products

2 One third 19" blank panel (P/N: 60-013199)

3 Download up-to-date Kramer user manuals from the Internet at this URL: <http://www.kramerelectronics.com>

4 For example, the SL-12, VP-2K, VS-21HD/CP-IR or VM-50HN

3.1 Recommendations for Best Performance

We recommend that you:

- Disconnect the power source and all cables connected to each machine that is being mounted in the rack adapter before proceeding with the installation
- Connect only good quality connection cables, thus avoiding interference, deterioration in signal quality due to poor matching, and elevated noise levels (often associated with low quality cables)
- Avoid interference from neighboring electrical appliances and position your rack adapter on the rack away from moisture, excessive sunlight and dust

4 Your Kramer RK-13 Rack Adapter

The example in Figure 1 illustrates the mounting of two 1/3-19" 1U units and one blank panel.

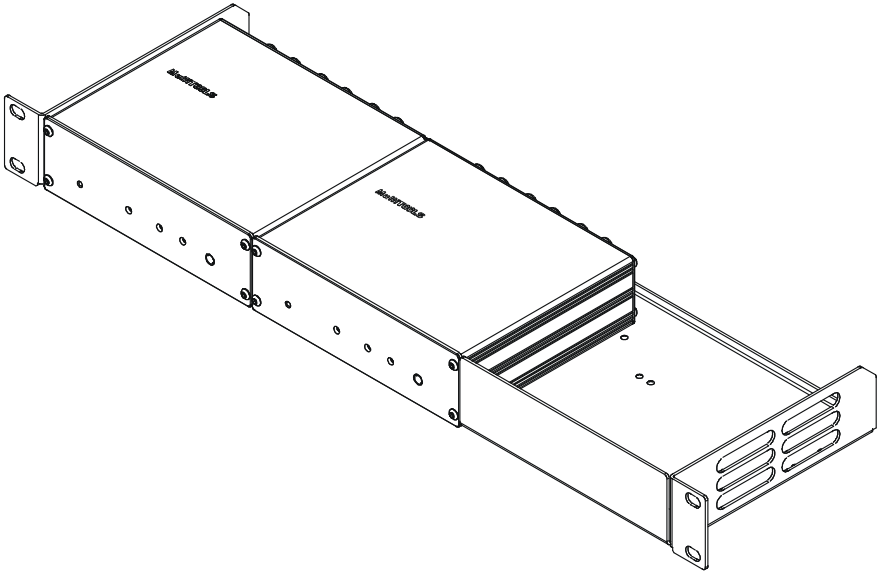

Figure 1: RK-13 Rack Adapter

You can order an additional blank panel to cover a second 1/3-19" 1U opening¹ on the **RK-13**

¹ Part number 60-013199

5 Mounting on the Kramer RK-13 Rack Adapter

The underside of the **RK-13** includes a set of screw holes that are suitable for mounting any combination of units.

To mount the units on the **RK-13**, as illustrated in Figure 1, do the following:

1. Place the first unit on the rack (for example, the Kramer **VP-2K**).
2. Hold both the **VP-2K** and the **RK-13** with your hands and turn them upside down.
3. Insert four M3x5 screws (supplied with the unit) through the holes on the **RK-13** that fit the holes on the underside of the **VP-2K** (as illustrated in Figure 2).
4. Tighten the screws.
5. Rotate the **RK-13** horizontally with the unit connected.
6. Place the next unit next to the unit that is already mounted.
7. Repeat steps 2 to 6 for each other unit.

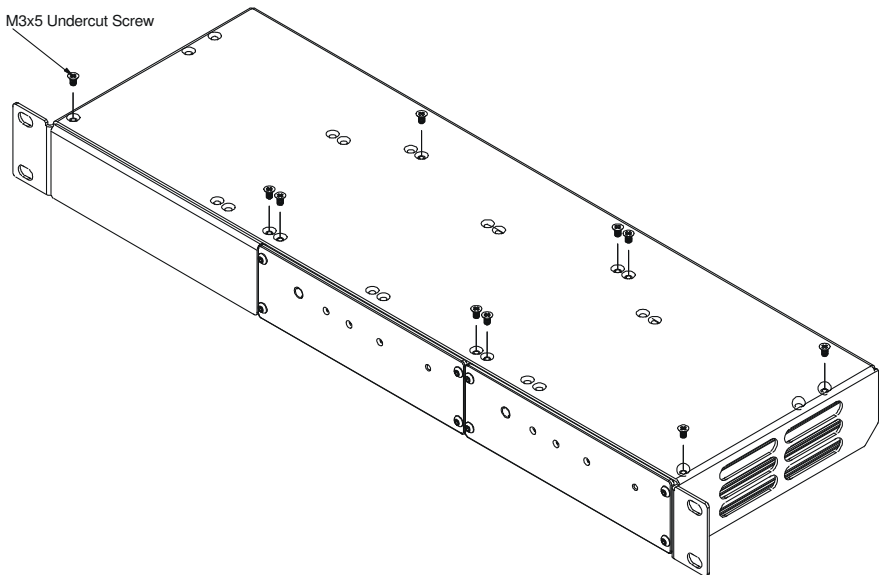

Figure 2: RK-13 Rack Adapter – Underside

5.1 Connecting a Blank Panel to the RK-13

You can connect a blank panel¹ to the **RK-13** to cover any empty spaces, as the example in Figure 3 illustrates:

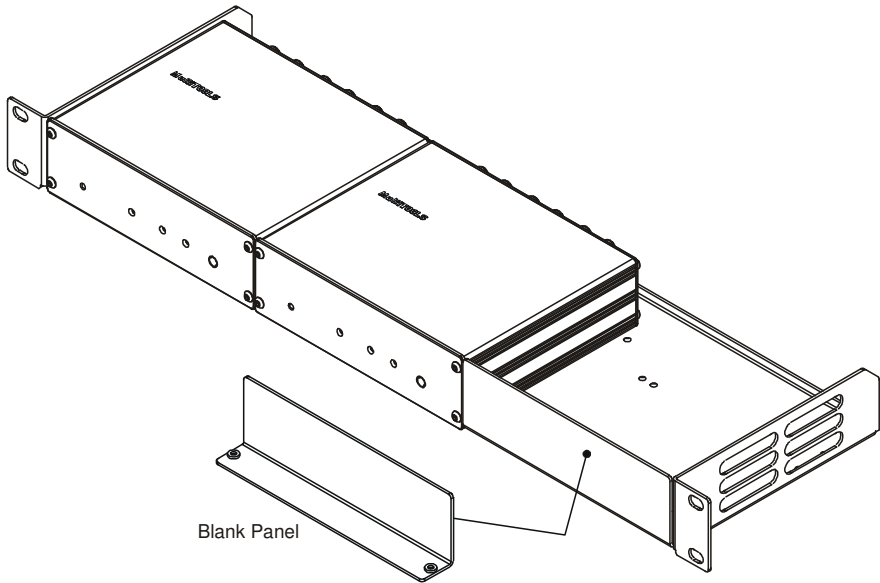

Figure 3: RK-13 Rack Adapter – Connecting a Blank Panel

6 Technical Specifications

Table 1 includes the technical specifications:

Table 1: Technical Specifications² of the RK-13

DIMENSIONS:	19-inch (W), 7-inch (D) 1U (H)
WEIGHT:	1.2kg. (2.65lbs.) approx.
ACCESSORIES:	15 M3x5 undercut screws, 1 third-19" 1U blank panel ³
OPTIONS:	Blank panels

¹ Specified in section 6

² Specifications are subject to change without notice

³ P/N: 60-013199

LIMITED WARRANTY

Kramer Electronics (hereafter *Kramer*) warrants this product free from defects in material and workmanship under the following terms.

HOW LONG IS THE WARRANTY

Labor and parts are warranted for seven years from the date of the first customer purchase.

WHO IS PROTECTED?

Only the first purchase customer may enforce this warranty.

WHAT IS COVERED AND WHAT IS NOT COVERED

Except as below, this warranty covers all defects in material or workmanship in this product. The following are not covered by the warranty:

1. Any product which is not distributed by Kramer, or which is not purchased from an authorized Kramer dealer. If you are uncertain as to whether a dealer is authorized, please contact Kramer at one of the agents listed in the Web site www.kramerelectronics.com.
2. Any product, on which the serial number has been defaced, modified or removed, or on which the WARRANTY VOID IF TAMPERED sticker has been torn, reattached, removed or otherwise interfered with.
3. Damage, deterioration or malfunction resulting from:
 - i) Accident, misuse, abuse, neglect, fire, water, lightning or other acts of nature
 - ii) Product modification, or failure to follow instructions supplied with the product
 - iii) Repair or attempted repair by anyone not authorized by Kramer
 - iv) Any shipment of the product (claims must be presented to the carrier)
 - v) Removal or installation of the product
 - vi) Any other cause, which does not relate to a product defect
 - vii) Cartons, equipment enclosures, cables or accessories used in conjunction with the product

WHAT WE WILL PAY FOR AND WHAT WE WILL NOT PAY FOR

We will pay labor and material expenses for covered items. We will not pay for the following:

1. Removal or installations charges.
2. Costs of initial technical adjustments (set-up), including adjustment of user controls or programming. These costs are the responsibility of the Kramer dealer from whom the product was purchased.
3. Shipping charges.

HOW YOU CAN GET WARRANTY SERVICE

1. To obtain service on you product, you must take or ship it prepaid to any authorized Kramer service center.
2. Whenever warranty service is required, the original dated invoice (or a copy) must be presented as proof of warranty coverage, and should be included in any shipment of the product. Please also include in any mailing a contact name, company, address, and a description of the problem(s).
3. For the name of the nearest Kramer authorized service center, consult your authorized dealer.

LIMITATION OF IMPLIED WARRANTIES

All implied warranties, including warranties of merchantability and fitness for a particular purpose, are limited in duration to the length of this warranty.

EXCLUSION OF DAMAGES

The liability of Kramer for any effective products is limited to the repair or replacement of the product at our option. Kramer shall not be liable for:

1. Damage to other property caused by defects in this product, damages based upon inconvenience, loss of use of the product, loss of time, commercial loss; or:
2. Any other damages, whether incidental, consequential or otherwise. Some countries may not allow limitations on how long an implied warranty lasts and/or do not allow the exclusion or limitation of incidental or consequential damages, so the above limitations and exclusions may not apply to you.

This warranty gives you specific legal rights, and you may also have other rights, which vary from place to place.

NOTE: All products returned to Kramer for service must have prior approval. This may be obtained from your dealer.

This equipment has been tested to determine compliance with the requirements of:

- EN-50081: "Electromagnetic compatibility (EMC);
generic emission standard.
Part I: Residential, commercial and light industry"
- EN-50082: "Electromagnetic compatibility (EMC) generic immunity standard.
Part I: Residential, commercial and light industry environment".
- CFR-47: FCC* Rules and Regulations:
Part 15: "Radio frequency devices
Subpart B Unintentional radiators"

CAUTION!

- Servicing the machines can only be done by an authorized Kramer technician. Any user who makes changes or modifications to the unit without the expressed approval of the manufacturer will void user authority to operate the equipment.
- Use the supplied DC power supply to feed power to the machine.
- Please use recommended interconnection cables to connect the machine to other components.
* FCC and CE approved using STP cable (for twisted pair products)





For the latest information on our products and a list of Kramer distributors, visit our Web site: www.kramerelectronics.com, where updates to this user manual may be found. We welcome your questions, comments and feedback.



Caution

Safety Warning:

Disconnect the unit from the power supply before opening/servicing.



P/N: 2900-000575



Rev: 1

Kramer Electronics, Ltd.

Web site: www.kramerelectronics.com

E-mail: info@kramerel.com

P/N: 2900-000575 REV 1