



## PA-150NET Quick Start Guide

This guide helps you install and use your product for the first time. For more detailed information, go to <http://www.kramerav.com/manual/PA-150NET> to download the latest manual or scan the QR code on the left.

### Step 1: Check what's in the box

- ✓ The PA-150NET Mono Power Amplifier
  - ✓ 1 Power adapter
- ✓ 4 Rubber feet
  - ✓ 1 Quick start guide

### Step 2: Install the PA-150NET

Attach the rubber feet and place on a table.

### Step 3: Connect the input and output

Always switch OFF the power on each device before connecting it to your PA-150NET.  
For best results, we recommend that you always use Kramer high-performance cables to connect AV equipment to the PA-150NET.

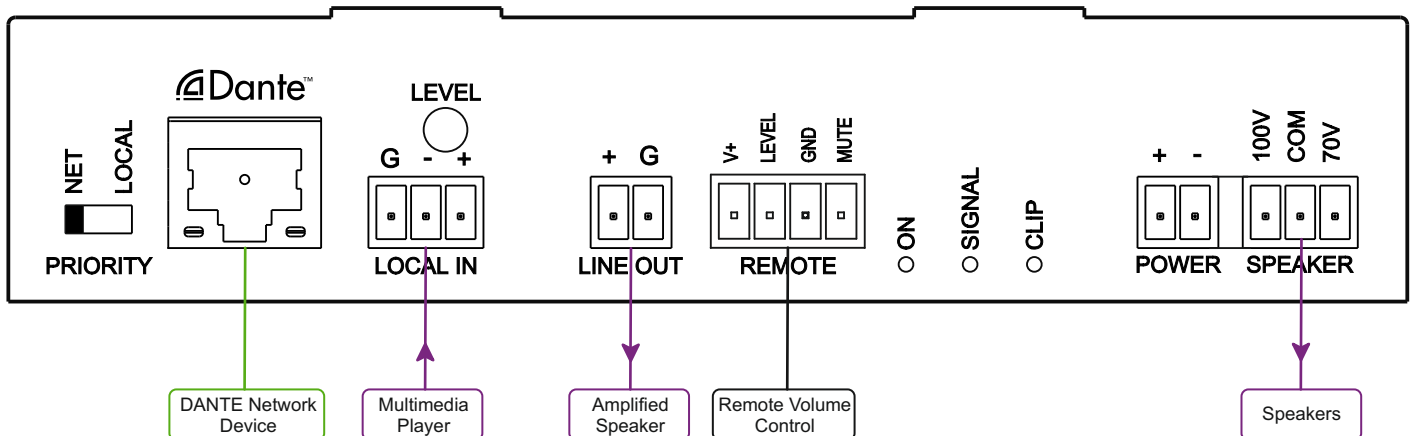

### Step 4: Connect the power

Connect the power adapter to the PA-150NET and plug it into the mains electricity

